

## Chapter 11

# Pipeline Rehabilitation by Sliplining with PE Pipe

### Introduction

An integral part of the infrastructure is the vast network of pipelines, conduits, and culverts in North America. These are among the assets we take for granted, since most are buried and we never see them. We do not see them deteriorate either, but we know that they do. Television inspection of the interiors of these systems often reveals misaligned pipe segments, leaking joints, or other failing pipe integrity.

The effects of continued deterioration of a pipeline could be quite drastic and costly. A dilapidated gravity sewer system permits substantial infiltration of groundwater, which increases the volume of flow and reduces the available hydraulic capacity of the existing line. So the old pipeline often increases treatment and transportation costs for the intended flow stream<sup>(24)</sup>. Continued infiltration may also erode the soil envelope surrounding the pipe structure and cause eventual subsidence of the soil.

The case for positive-pressure pipelines is somewhat different, but the results are equally unacceptable. In this situation, continued leakage through the existing pipeline allows exfiltration of the contents of the flow stream that eventually leads to extensive property damage or water resource pollution. Also, in many cases, the contents of the flow stream are valuable enough that their loss through exfiltration becomes another economic factor. PE pipe provides an excellent solution to the problem of leaky joints, whether it is due to infiltration or to exfiltration. This is because the standard method of joining PE pipe uses a heat fusion process that results in a monolithic pipe system, that is, the joints are as strong as, and as leak free, as the pipe itself.

When the harmful results of pipeline deterioration become apparent, we must either find the most economical method that

will restore the original function or abandon the failed system. Excavation and replacement of the deteriorating structure can prove prohibitively expensive and will also disrupt the service for which the original line is intended<sup>(18)</sup>. An alternate method for restoration is “sliplining” or “insertion renewal” with polyethylene pipe. More than 30 years of field experience shows that this is a proven cost-effective means that provides a new pipe structure with minimum disruption of service, surface traffic, or property damage that would be caused by extensive excavation.

The sliplining method involves accessing the deteriorated line at strategic points within the system and subsequently inserting polyethylene pipe lengths, joined into a continuous tube, throughout the existing pipe structure. This technique has been used to rehabilitate gravity sewers<sup>(11, 24)</sup>, sanitary force mains, water mains, outfall lines, gas mains<sup>(2, 13)</sup>, highway and drainage culverts<sup>(18)</sup>, and other piping structures with extremely satisfactory results. It is equally appropriate for rehabilitating a drain culvert 40-feet long under a road or straight sewer line with manhole access as far as 1/2 mile apart. The technique has been used to restore pipe as small as 1-inch, and there are no apparent maximum pipe diameters.

Mechanical connections are used to connect PE pipe systems to each other and to connect PE pipe systems to other pipe materials and systems. The reader can refer to the Handbook chapter that is titled ‘Polyethylene Joining Procedures’ for additional information on Mechanical Connections and Mechanical Joint (MJ) Adapters.

## Design Considerations

The engineering design procedure required for a sliplining project consists of five straightforward steps:

1. Select a pipe liner diameter.
2. Determine a liner wall thickness.
3. Determine the flow capacity.
4. Design necessary accesses such as terminal manholes, headwall service and transition connections.
5. Develop the contract documents.

## Select a Pipe Liner Diameter

To attain a maximum flow capacity, select the largest feasible diameter for the pipe liner. This is limited by the size and condition of the original pipe through which it will be inserted. Sufficient clearance will be required during the sliplining process to insure trouble-free insertion, considering the grade and direction, the severity of any offset joints, and the structural integrity of the existing pipe system.

The selection of a polyethylene liner that has an outside diameter 10% less than the inside diameter of the pipe to be rehabilitated will generally serve two purposes. First, this size differential usually provides adequate clearance to accommodate the insertion process. Second, 75% to 100% or more of the original flow capacity may be maintained. A differential of less than 10% may provide adequate clearance in larger diameter piping structures. It is quite common to select a 5% to 10% differential for piping systems with greater than 24-inch diameters, assuming that the conditions of the existing pipe structure will permit insertion of the liner.

## Determine a Liner Wall Thickness

### Non-Pressure Pipe

In the majority of gravity pipeline liner projects, the principal load that will act on the polyethylene pipe is the hydrostatic load that is created when the water table rises above the crown (top) of the liner.

The generic Love's equation (Eq. 1) shows that the ability of a free-standing pipe to withstand external hydrostatic loading is essentially a function of the pipe wall moment of inertia and the apparent modulus of elasticity of the pipe material. The critical buckling pressure,  $P_c$  for a specific pipe construction can be determined by using equation Eq. 1.

### (1) Love's Equation

$$P_c = \frac{24EI}{(1 - \nu^2) \times D_m^3} \times f_0$$

### WHERE

$P_c$  = Critical buckling pressure, psi

$E$  = Apparent modulus of elasticity (Refer to Appendix, Chapter 3, for the appropriate value for the Material Designation Code of the PE pipe being used and the applicable service conditions.)

$I$  = Pipe wall moment of inertia, in<sup>4</sup>/in

=  $t^3/12$  for solid wall PE, where  $t$  = minimum wall thickness of the pipe, in

$\nu$  = Poisson's Ratio, 0.45 for all PE pipe materials

$D_m$  = Mean diameter, inches (outside diameter minus one wall thickness)

$f_0$  = Ovality compensation factor, dimensionless (see Figure 1)

$D$  = Pipe average outside diameter, in

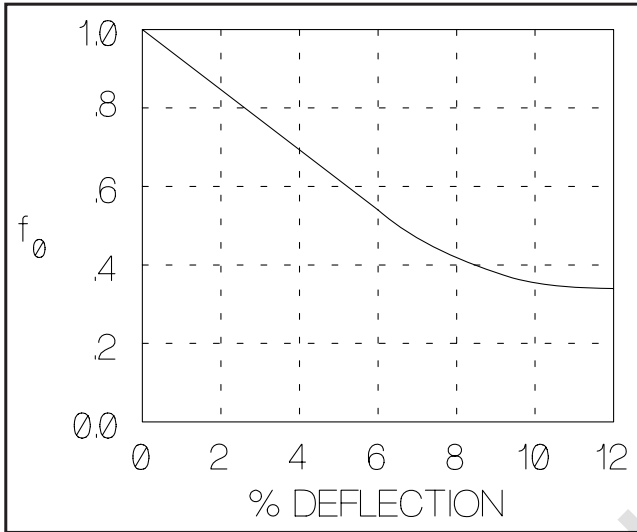

**Figure 1** % Deflection vs. Ovality Correction Factor,  $f_0$

where % Deflection =  $\frac{D - D_{\min}}{D} \times 100$

$D_{\min}$  = Pipe minimum diameter, in

To compute the buckling pressure of a dimension ratio (DR) series polyethylene pipe (i.e., a grouping of solid wall pipes of different diameters but with the same ratio of specified outside diameter to minimum wall thickness), the following variation of Love's equation<sup>(22)</sup>, Eq. 2, is used.

**(2) Love's Equation for DR Solid Wall Pipe**

$$P_c = E \times \left( \frac{2}{1 - \nu^2} \right) \times \left( \frac{1}{DR - 1} \right)^3 \times f_0$$

**WHERE**

**DR** = Dimension ratio, dimensionless (OD/t)

**OD** = Actual outside diameter, inches

**t** = Minimum wall thickness, inches

The process of calculating the buckling resistance of a free-standing pipe is iterative in that, once the critical buckling resistance of a trial choice has been determined, it can be compared to the anticipated hydrostatic load. If the pipe's calculated buckling resistance is significantly larger than the anticipated hydrostatic loading, the procedure can be used to evaluate a lesser wall thickness (with the advantages of lighter weight materials and lower costs). The prudent practice is to select a design

buckling resistance that provides an adequate safety factor (SF) over the maximum anticipated hydrostatic load.

**(3) Safety Factor, SF**

$$SF = \frac{P_c}{\text{Anticipated Hydrostatic Load}}$$

For an example of the calculations that can be made with Equations 2 and 3, consider a 22-inch DR 26 solid-wall polyethylene liner placed within a 24-inch clay tile pipe and subjected to a maximum excess hydrostatic load of 3 feet of water table.

1. Calculate the equivalent hydrostatic load in psi.  
Water load = 3 ft x 62.4 lb/ft<sup>3</sup> x 1 ft<sup>2</sup>/144 in<sup>2</sup> = 1.3 psi
2. Calculate the critical buckling pressure, P<sub>c</sub>, using Eq. 2 assuming the following variable values: E = 28,200 psi, ν = 0.45 and f<sub>0</sub> = 0.79
3. Calculate the Safety Factor, SF, from Eq. 3 for this load assumption.  
SF = 3.6/1.3 = 2.8

A safety factor of 2.0 or greater is often used for frequent or long-term exposure to such loads. If a larger safety factor is preferred, repeat the procedure for a heavier wall configuration or consider the enhancement of the pipe’s buckling strength by the effects of external restraint.

Love’s equation assumes that the liner being subjected to the indicated hydrostatic load is free-standing and is not restrained by any external forces. Actually, the existing pipe structure serves to cradle the flexible liner, enhancing its collapse resistance. Maximum external reinforcement can be provided, where required, by placing a stable load-bearing material such as cement, fly ash, polyurethane foam, or low-density grout in the annular space between the liner and the existing pipe. Studies show that filling the annular cavity will enhance the collapse resistance of a polyethylene pipe by at least a four-fold factor and often considerably more, depending on the load-bearing capabilities of the particular fill material. Contact the pipe suppliers for additional information.

For solid wall PE pipe, the significant variable that determines adequate wall stiffness is the pipe DR. It is a simple matter to specify the DR once the amount of the loading on the pipe is determined. A typical manufacturer’s recommendation for safe long-term (50-year) external pressure loading might follow the guidelines in Table 1, which were derived according to the procedure shown in ASTM F585, Practice for Insertion of Flexible Polyethylene Pipe into Existing Sewers.

**TABLE 1**  
**Allowable Height<sup>(1)</sup> of Water Above DR Dimensioned Pipe at the Maximum Operating Temperature of 73°F (23°C)<sup>(2)</sup> and Under a Continuous Duration of Loading of 50-years<sup>(3)</sup>. Not Grouted vs. Grouted Pipe**

Pipe Dimension Ratio (DR)	Height of water (feet) above pipe made from materials designated as PE 4XXX <sup>(4)</sup>		Height of water (feet) above pipe made from materials designated as PE 3XXX <sup>(4)</sup>	
	Not Grouted	Grouted	Not Grouted	Grouted
32.5	2.0	10.0	1.9	9.5
26	4.0	20.0	3.9	19.5
21	7.9	39.5	7.6	38.0
17	15.4	77.0	14.8	74.0
13.5	32.2	161.0	31.1	155.0
11	62.9	314.5	60.8	304.0

Notes:

- (1) The values of allowable height were computed by means of equation (2) and under the following assumptions:
  - The apparent modulus E is 28,000 psi for PE3XXX and 29,000 psi for PE4XXX materials at 73°F and for a 50-year load duration; refer to Appendix, Chapter 3 of this Handbook.
  - The value of Poisson's ratio ( $\mu$ ) is 0.45
  - The value of  $f_0$ , the pipe ovality correction factor, is 0.75, which corresponds to a pipe deflection of 3%
  - A safety factor of 2.0 was used. See preceding discussion on selecting an appropriate safety factor
  - For grouted applications, the height of water above pipe was computed by multiplying by 5 the height obtained for the corresponding non-grouted applications.
- (2) Table B.1.2 of the Appendix of Chapter 3 lists temperature adjusting factors which may be used to convert the above results to other maximum operating temperatures
- (3) Values for apparent modulus for other periods of continuous loading are listed in Table B.1.1 in the Appendix of Chapter 3
- (4) The first numeral after PE is the standard classification for the PE's density. The X's designate any recognized value for the other coded properties. See the section on Structural Properties of Chapter 3 for a detailed description of the PE piping material designation code.

The figures in this table represent a Safety Factor, SF, of 2.0 and a diametrical ovality of 3%. Grouted strength of the pipe was derived by applying a multiplier of 5 to the non-grouted value<sup>(32)</sup>. If the existing sewer will not provide structural integrity to earth and live loads, a more conservative Safety Factor should be used.

For profile wall pipe the variable that determines adequate wall stiffness is a function of the pipe wall moment of inertia and pipe inside mean diameter. The following equation can be used to estimate maximum allowable long-term (50-year) height of water above the pipe with no grout:

$$(4) \quad H = \frac{0.9 \times RSC}{D_m}$$

**WHERE**

**H = Height of water, feet**

**RSC = Measured Ring Stiffness Constant**

**D<sub>m</sub> = Mean diameter, inches**

This equation contains a Safety Factor (SF) of 2.0 based on pipe with a maximum 3% deflection.

For grout with a minimum compressive strength of 500 psi at 24 hours (1,800 psi at 28 days), the allowable long-term (50-year) height of water above the pipe may be determined from the following equation:

$$^{(5)} H = 5 \times \frac{(0.9 \times RSC)}{D_m}$$

This equation contains a Safety Factor (SF) of 2.0.

### Pressure Pipe

A liner, which will be exposed to a constant internal pressure or to a combination of internal and external stresses must be analyzed in a more detailed manner. The guidelines for a detailed loading analysis such as this are available from a variety of resources that discuss in detail the design principles concerned with underground installation of flexible piping materials.<sup>(3,15,16,19,26,29)</sup> The reader is also advised to refer to Chapters 3 and 6 of this Handbook for additional information on design principles and the properties applicable to the particular Material Designation Code of the PE pipe being used.

In those installations where the liner will be subjected to direct earth loading, the pipe/soil system must be capable of withstanding all anticipated loads. These include earth loading, hydrostatic loading, and superimposed loads. The structural stability of a polyethylene liner under these conditions is determined largely by the quality of the external support. For these situations, refer to any of the above referenced information sources that concern direct burial of thermoplastic pipe. A polyethylene liner that has been selected to resist hydrostatic loading will generally accommodate typical external loading conditions if it is installed properly.

### Other Loading Considerations

Filling of the entire annular space is rarely required. If it is properly positioned and sealed off at the termination points, a polyethylene liner will eliminate the sluice path that could contribute to the continued deterioration of most existing pipe structures. With a liner, a gradual accumulation of silt or sediment occurs within the annular space, and this acts to eliminate the potential sluice path.

On occasion, deterioration of the original pipe may continue to occur even after the liner has been installed.<sup>(8)</sup> This situation may be the result of excessive ground-water movement combined with a soil quality that precludes sedimentation within the annular space. Soil pH and resistivity can also help deteriorate the host culvert or pipe. As a result, uneven or concentrated point loading upon the pipe liner or even subsidence of the soil above the pipe system may occur. This can be avoided by filling the annular space with a cement-sand mixture, a low-density grout material<sup>(10)</sup>, or fly ash.

## Determine the Flow Capacity

The third step in the sliplining process is to assess the impact of sliplining on the hydraulic capacity of the existing pipe system. This is accomplished by using commonly-accepted flow equations to compare the flow capacity of the original line against that of the smaller, newly-installed polyethylene liner. Two equations widely used for this calculation are the Manning Equation (Eq. 6) and the Hazen-Williams Approximation for other than gravity flow systems (Eq. 7).<sup>(2,5)</sup> The reader is referred to Chapter 6 of this Handbook, where the subject of fluid flow is covered extensively.

### (6) Manning Equation for Gravity Flow

$$Q = \frac{1.486 \times A \times R^{0.667} \times S^{0.5}}{n}$$

#### WHERE

Q = Flow, ft<sup>3</sup>/sec

A = Flow area, ft<sup>2</sup> (3.14 x ID<sup>2</sup>/4)

R = Hydraulic radius, feet (ID/4 for full flow)

S = Slope, ft/ft

n = Manning flow factor for piping material, 0.009 for smooth wall PE

ID = Inside diameter, feet

For circular pipe flowing full, the formula may be simplified to

$$Q = \frac{0.463 \times ID^{2.667} \times S^{0.5}}{n}$$

### (7) Hazen-Williams Approximation for Other Than Gravity Flow

$$H = \frac{1044 \times G^{1.85}}{C_H^{1.85} \times ID^{4.865}}$$

#### WHERE

H = Friction loss in ft of H<sub>2</sub>O/100 ft

G = Volumetric flow rate, gpm

$$= 2.449 \times V \times ID^2$$

V = Flow velocity, ft/sec

ID = Inside diameter, inches

C<sub>H</sub> = Hazen Williams flow coefficient, dimensionless

$$= 150 \text{ for smooth wall polyethylene}$$

The insertion of a smaller pipe within the existing system may appear to reduce the original flow capacity. However, in the majority of sliplining applications, this is not the case. The polyethylene liner is extremely smooth in comparison to most piping materials. The improved flow characteristic for clear water is evidenced by



a comparatively low Manning Flow Coefficient,  $n$  of 0.009, and a Hazen-Williams coefficient,  $C_H$ , of 150.

While a reduction in pipe diameter does occur as a consequence of sliplining, it is largely compensated by the significant reduction in the Manning Flow Coefficient. As a result, flow capacity is maintained at or near the original flow condition.<sup>(18)</sup> Manning Flow Coefficients and Hazen-Williams Flow Coefficients for a variety of piping materials are listed in Table 2a and 2b. These factors may be used to approximate the relative flow capacities of various piping materials.

**TABLE 2A**  
Typical Manning Flow Coefficients for Water Flowing through Common Piping Materials

Polyethylene (solid wall)	0.009
PVC	0.009
Cement-lined Ductile Iron	0.012
New Cast Iron, Welded Steel	0.014
Wood, Concrete	0.016
Clay, New Riveted Steel	0.017
Old Cast Iron, Brick	0.020
CSP	0.023
Severely Corroded Cast Iron	0.035

**TABLE 2B**  
Typical Hazen-Williams Flow Coefficients for Water Flowing through Common Piping Materials<sup>(31)</sup>

Polyethylene (solid wall)	150
PVC	150
Cement-lined Ductile Iron	140
New Cast Iron, Welded Steel	130
Wood, Concrete	120
Clay, New Riveted Steel	110
Old Cast Iron, Brick	100
Severely Corroded Cast Iron	80

Quite often the hydraulic capacity of a gravity flow pipe can actually be improved by an insertion renewal. For example, consider the following illustrations of calculations using the Manning Equation (Eq. 6).

**Calculation for Flow Rate,  $Q$ , through a 24-inch ID Concrete Pipe at 1% slope (1 ft/100 ft)**

$$Q = \frac{1.486 \times 3.14 \times 1^2 \times 0.5^{0.667} \times 0.01^{0.5}}{0.016} = 18.3 \text{ ft}^3/\text{sec} \text{ (8,248 gpm)}$$

**Calculation of Flow Rate, Q, through a 22-inch OD Polyethylene Pipe with a 20.65-Inch ID at 1% slope (1 ft/100 ft)**

$$Q = \frac{1.486 \times 3.14 \times 0.8604^2 \times 0.429^{0.667} \times 0.01^{0.5}}{0.009} = \mathbf{21.8 \text{ ft}^3/\text{sec} \text{ (9,800 gpm)}}$$

Comparison of the two calculated flow rates shows that sliplining this 24-inch concrete pipe with the smaller polyethylene pipe actually improves the capacity by 1,000 gallons per minute. This will often be the situation. Occasionally, the theoretical flow capacity of the liner may appear to be equivalent to or slightly less than that of the original system. In many such cases, the presence of the liner eliminates the infiltration associated with the deterioration of the original pipe and the corresponding burden this places on the existing flow capacity. So an apparently small reduction in theoretical flow capacity may, in reality, prove to be quite acceptable since it eliminates the infiltration and the effect this produces on available hydraulic capacity.

### Design the Accesses

The polyethylene liner will need to be connected to existing system components or appurtenances. Proper planning for a rehabilitation project must include the specific engineering designs by which these connections will be made.

Gravity flow pipeline rehabilitation often requires that the individual liner lengths be terminated at manholes or concrete headwalls that already exist within the system that is being sliplined. The annular space at these locations must provide a water-tight seal against continued infiltration in the void area that exists between the liner and the original pipe where they connect to these structures.

Typically, the required seal can be made by compacting a ring or collar of Okum saturated with non-shrink grout into the void area to a distance equal to one-half to one full liner diameter. The annular space is then “dressed” with a non-shrink elastomeric grout. The face of the elastomeric grout may then be covered with a quick-set chemical-resistant concrete. The same concrete material may then be used to reconstruct an invert in the manhole. This type of seal is shown in Figure 2.

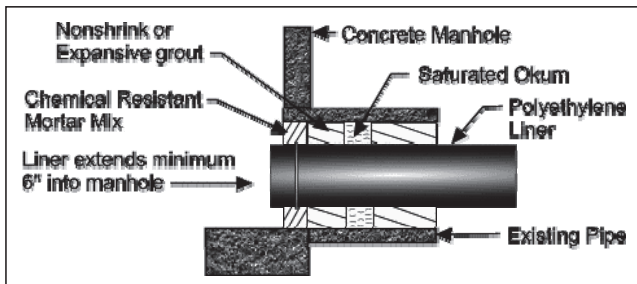

**Figure 2** Typical Manhole Seal for Gravity Flow Applications

For those installations where a new manhole or headwall will be set, the amount of elastomeric grout may be minimized by fusing a water-stop or stub end onto the liner length before it is finally positioned. This fitting may then be embedded within the poured headwall or grouted into the new manhole. Some typical connecting arrangements for newly constructed appurtenances are shown in Figure 3. The connection described (water stop/wall anchor grouted in place) can also work on existing structures.

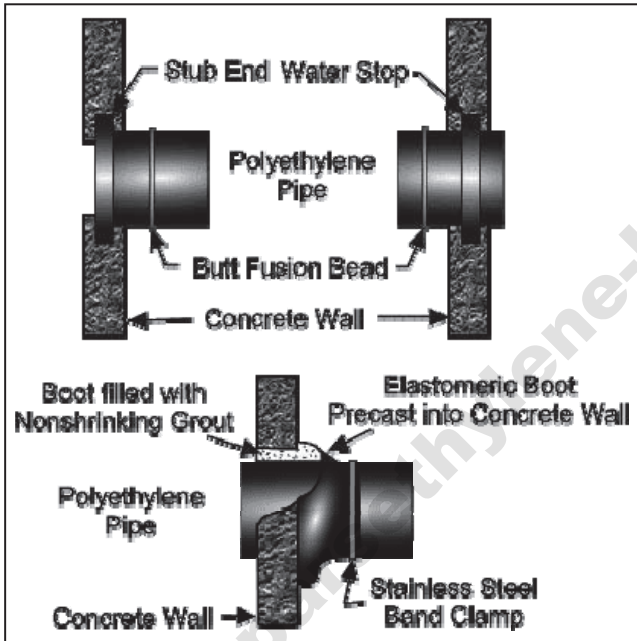

**Figure 3** Newly Constructed Headwall or Manhole Placements

Deteriorated lateral service connections are a leading cause of infiltration in gravity flow pipelines.<sup>(19)</sup> An integral part of the insertion process is rebuilding these connections. This aspect of sliplining assures maximum reduction of infiltration, provides for long-term structural stability of the service, and minimizes the potential for continued deterioration of the existing pipe system.

Individual home services or other laterals may be connected to the liner by using any of several different connection methods. For example, upon relaxation of the liner, sanitary sewer connections may be made to the polyethylene liner by using a strap-on service saddle or a side-wall fusion fitting. Either of these options provides a secure water-tight connection to the liner and allows for effective renewal of the riser with no reduction in the inside diameter of the service. Both of these types of connection are shown in Figure 4.

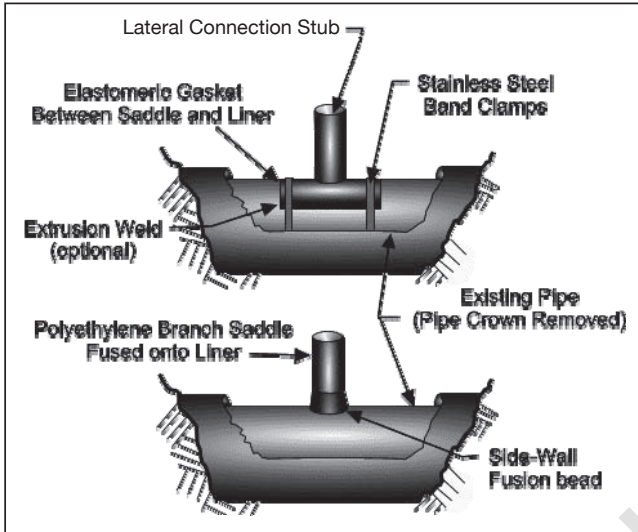

Figure 4 Lateral Service Connections for Sliplining Gravity Pipelines

Rehabilitation of pressure pipelines often requires that connections be made to lateral pressure-rated piping runs. Connections to these lines should be designed to insure full pressure capability of the rehabilitated system. Several alternatives are available to meet this requirement. These include in-trench fusion of molded or fabricated tees, sidewall fusion of branch saddles, insertion of spool pieces via electrofusion and insertion of low-profile mechanical connectors. One of these options is illustrated schematically in Figure 5. Performance requirements and installation parameters of the rehabilitation project most often dictate the selection of one specific connection design.

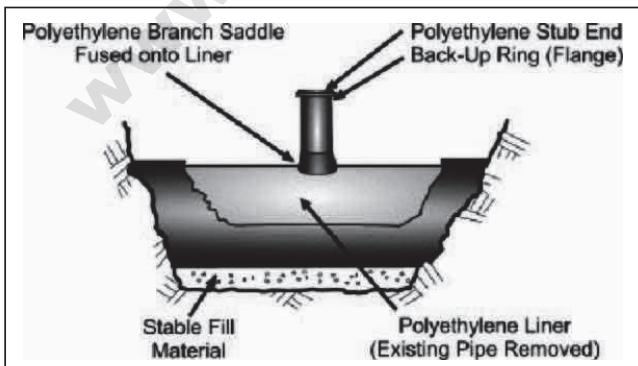

Figure 5 Typical Lateral Service Connection for Sliplining Pressure Pipelines

## Develop the Contract Documents

When the rehabilitation design has been completed, attention will be focused on writing the specifications and contract documents that will ensure a successful installation. Reference documents for this purpose include: ASTM D3350<sup>(4)</sup>, ASTM F585<sup>(5)</sup>, ASTM F714<sup>(6)</sup>, and ASTM F894.<sup>(7)</sup> To assist further in the development of these documents, a model sliplining specification is available from the Plastics Pipe Institute, "Guidance and Recommendations on the Use of Polyethylene (PE) Pipe for the Sliplining of Sewers."

## The Sliplining Procedure

The standard sliplining procedure is normally a seven-step process. While the actual number of steps may vary to some degree in the field, the procedure remains the same for all practical purposes.<sup>(23,24)</sup> The procedures for rehabilitation of gravity and positive pressure pipelines are essentially the same. Some subtle differences become apparent in the manner by which some of the basic steps are implemented. The seven basic steps are as follows:

1. Inspect the existing pipe.
2. Clean and clear the line.
3. Join lengths of polyethylene pipe.
4. Access the original line.
5. Installation of the liner.
6. Make service and lateral connections.
7. Make terminal connections and stabilize the annular space.

### 1. Inspect the Existing Pipe

The first step for a sliplining project is the inspection of the existing pipe. This will determine the condition of the line and the feasibility of insertion renewal. During this step, identify the number and the locations of offset pipe segments and other potential obstructions.

Use a remote controlled closed circuit television camera to inspect the pipe interior. As the unit is pulled or floated through the original pipe, the pictures can be viewed and recorded with on-site television recording equipment.

### 2. Clean and Clear the Line

The existing pipeline needs to be relatively clean to facilitate placement of the polyethylene liner. This second step will ensure ease of installation. It may be

accomplished by using cleaning buckets, kites or plugs, or by pulling a test section of polyethylene liner through the existing pipe structure.

Obviously, to attempt a liner insertion through a pipeline obstructed with excess sand, slime, tree roots or deteriorated piping components would be uneconomical or even impossible. Step 2 is often undertaken in conjunction with the inspection process of Step 1.

### 3. Weld Lengths of Polyethylene Pipe

Polyethylene pipe may be joined by butt fusion technology, gasketed bell and spigot joining methods, or by extrusion welding. The specific method to be used will be determined by the type of polyethylene pipe being inserted into the existing pipe structure. Solid wall polyethylene pipe is usually joined using butt fusion techniques. Polyethylene profile walled pipe, on the other hand, can be joined by integral gasketed bell and spigot joining methods or by the extrusion welding technique. Consult the manufacturer for the recommended procedure.

#### **Butt Fusion — Solid Wall Pipe**

Individual lengths of solid wall polyethylene pipe are joined by using the butt fusion process technique. The integrity of this joining procedure is such that, when it is performed properly, the strength of the resulting joint equals or exceeds the structural stability of the pipe itself. This facilitates the placement of a leak-free liner throughout the section of the existing system under rehabilitation.

The external fusion bead, formed during the butt fusion process, can be removed following the completion of joint quality assurance procedures by using a special tool prior to the insertion into the existing system. The removal of the bead may be necessary in cases of minimal clearance between the liner and the existing pipeline, but otherwise not required.

#### **Pulling Lengths**

Individual pulling lengths are usually determined by naturally occurring changes in grade or direction of the existing pipe system. Severe changes in direction that exceed the minimum recommended bending radius of the polyethylene liner may be used as access points. Likewise, severe offset joints, as revealed during the television survey, are commonly used as access points. By judicious planning, potential obstructions to the lining procedure may be used to an advantage.

There is a frequent question regarding the maximum pulling length for a given system. Ideally, each pull should be as long as economically possible without exceeding the tensile strength of the polyethylene material. It is rare that a pull of this magnitude is ever attempted. As a matter of practicality, pulling lengths are

more often restricted by physical considerations at the job site or by equipment limitations.<sup>(2,3)</sup>

To ensure a satisfactory installation, the designer may want to analyze what is considered the maximum pulling length for a given situation. Maximum pulling length is a function of the tensile strength and weight of the polyethylene liner, the temperature at which the liner will be manipulated, the physical dimensions of the liner, and the frictional drag along the length of the polyethylene pipe liner.

Equations 8 and 9 are generally accepted for determination of the maximum feasible pulling length. One of the important factors in these calculations is the tensile strength of the particular polyethylene pipe product, which must be obtained from the manufacturer's literature.

**(8) Maximum Pulling Force, MPF**

$$MPF = f_y \times f_t \times T \times \pi \times OD^2 \left( \frac{1}{DR} - \frac{1}{DR^2} \right)$$

**WHERE**

**MPF** = Maximum pulling force, lb-force

**f<sub>y</sub>** = Tensile yield design (safety) factor, 0.40

**f<sub>t</sub>** = Time under tension design (safety) factor, 0.95\*

**T** = Tensile yield strength, psi (Refer to Appendix, Chapter 3, for the appropriate value for the Material Designation Code of the PE pipe being used and the applicable service conditions.)

**OD** = Outside diameter, inches

**DR** = Dimension Ration, dimensionless

\* The value of 0.95 is adequate for pulls up to 12 hours.

**(9) Maximum Pulling Length, MPL**

$$MPL = \frac{MPF}{W \times CF}$$

**WHERE**

**MPL** = Maximum straight pulling length on relatively flat surface, ft

**MPF** = Maximum pulling force, lb-force (Eq. 8)

**W** = Weight of pipe, lbs/ft

**CF** = Coefficient of friction, dimensionless

= 0.1, flow present through the host pipe

= 0.3, typical for wet host pipe

= 0.7, smooth sandy soil

### Profile Wall Pipe

Profile wall PE pipe is available in the market place in different or unique wall constructions. Some of these products feature bell and spigot gasket type joint assembly; others are joined using one or more of the various heat fusion techniques such as, extrusion welding, butt fusion, and or electrofusion. The products having the bell and spigot gasketed joint arrangement must be pushed or “jacked” rather than pulled, into the line being rehabilitated. Because of this and the many other differences, it is not instructive or beneficial to try and cover all of these special products in this Handbook. Therefore, the reader who may have interest in learning more about the design and application of these products for pipeline rehabilitation service, is advised to consult directly with the product supplier.

#### 4. Access the Original Line

Excavation of the access pits is the next step in the insertion renewal procedure. Access pits will vary considerably in size and configuration, depending on a number of project-related factors such as:

- Depth of the existing pipe
- Diameters of the liner and the existing pipe
- Stiffness of liner pipe
- Prevailing soil conditions
- Equipment availability
- Traffic and service requirements
- Job site geography

For example, a fairly large access pit may be required when attempting to slipline a large diameter system that is buried deep in relatively unstable soil. In contrast, the access pit for a smaller diameter pipeline that is buried reasonably shallow (5 to 8 feet) may be only slightly wider than the liner itself. In actual practice, the simpler situation is more prevalent. An experienced contractor will recognize the limiting factors at a particular job site and utilize them to the best economic advantage, thus assuring a cost-effective installation.

A typical access pit for sliplining with pre-fused or welded lengths of solid wall polyethylene pipe is illustrated in Figure 6. Figure 7 is a schematic of an access method that may be used with profile pipe.



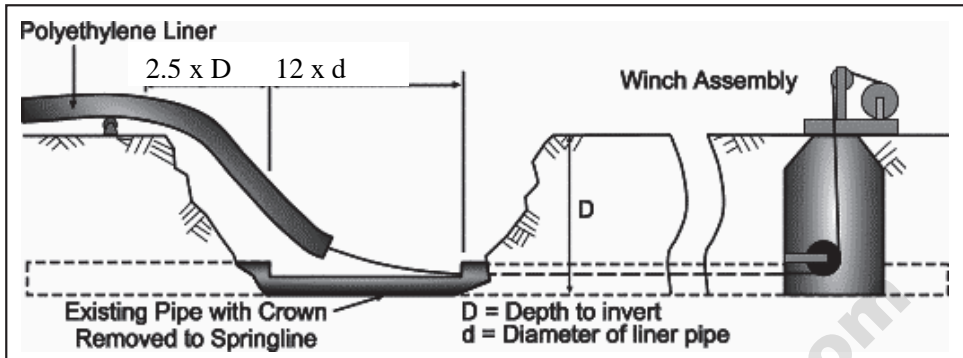

**Figure 6** Typical Sliplining Access Pit for Prefused Lengths of Polyethylene Liner

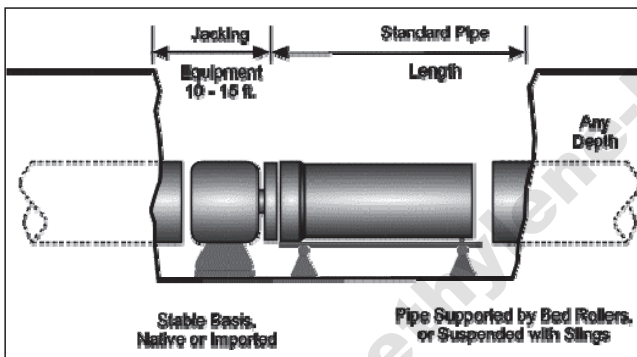

**Figure 7** Typical Sliplining Access Pit for Bell and Spigot Polyethylene Liner

## 5. Installation of the Liner

Insertion of the polyethylene liner may be accomplished by one of several techniques. Prefused or welded lengths of solid wall polyethylene pipe may be “pulled” or “pushed” into place. Gasket-Jointed profile pipe, on the other hand, must be installed by the push method to maintain a water-tight seal.

### The “Pulling” Technique

Prefused or welded lengths of polyethylene liner may be pulled into place by using a cable and winch arrangement. The cable from the winch is fed through the section of pipe that is to be sliplined. Then the cable is fastened securely to the liner segment, thus permitting the liner to be pulled through the existing pipe and into place.

Figure 6 is a schematic of an installation in which the liner is being pulled through the existing pipe from the left side toward a manhole at the right. This procedure requires some means, such as a pulling head, to attach the cable to the leading edge of the liner. The pulling head may be as simple or as sophisticated as the particular project demands or as economics may allow.

The pulling head may be fabricated of steel and fastened to the liner with bolts. They are spaced evenly around the circumference of the profile so that a uniform pulling force is distributed around the pipe wall. This type of fabricated pulling head will usually have a conical shape, aiding the liner as it glides over minor irregularities or through slightly offset joints in the old pipe system. The mechanical pulling head does not normally extend beyond the Outside Diameter (O.D.) of the polyethylene liner and is usually perforated to accommodate flow as quickly as possible once the liner is inserted inside the old system. Three practical styles of typical mechanical pulling heads are shown in Figure 8.

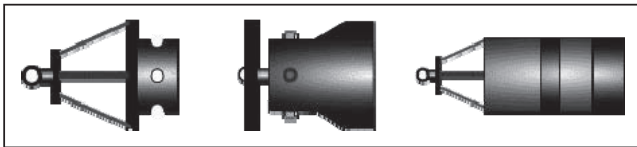

Figure 8 Fabricated Mechanical Pulling Heads

A less sophisticated but cost-effective approach is to fabricate a pulling head out of a few extra feet of liner that has been fused onto a single pipe pull. Cut evenly spaced wedges into the leading edge of the extra liner footage, making it look like the end of a banana being peeled. Collapse the ends toward the center and fasten them together with bolts or all-thread rods. Then attach the cable to secondary bolts that extend across the collapsed cross section. This simple technique is illustrated in Figure 9.

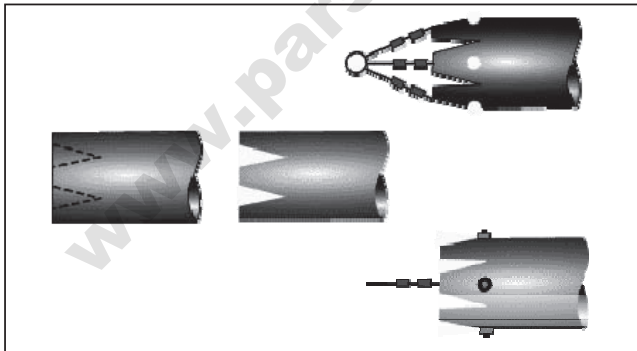

Figure 9 Field-Fabricated Pulling Heads

As the polyethylene liner is pulled into the pipeline, a slight elongation of the liner may occur. A 24-hour relaxation period will allow the liner to return to its original dimensions. After the relaxation period, the field fabricated pulling head may be cut off. It is recommended the liner be pulled past the termination point by 3-5%. This allows the liner to be accessible at the connection point after the relaxation period.

The pull technique permits a smooth and relatively quick placement of the liner within an old pipe system. However, this method may not be entirely satisfactory when attempting to install a large-diameter heavy-walled polyethylene pipe. This is especially true when the load requires an unusually large downstream winch. A similar problem may exist as longer and larger pulls are attempted so that a heavier pulling cable is required. When the pull technique is not practical, consider the advantages that may be offered by the push technique.

### The “Push” Technique

The push technique for solid wall or welded polyethylene pipe is illustrated schematically in Figure 10. This procedure uses a choker strap, placed around the liner at a workable distance from the access point. A track-hoe, backhoe, or other piece of mechanical equipment pulls the choker to push the liner through the existing pipe. With each stroke of the backhoe, the choker grips the pipe and pushes the leading edge of the liner further into the deteriorated pipe. At the end of each stroke, the choker must be moved back on the liner, usually by hand. The whole process may be assisted by having a front-end loader or bulldozer simultaneously push on the trailing end of the liner segment.

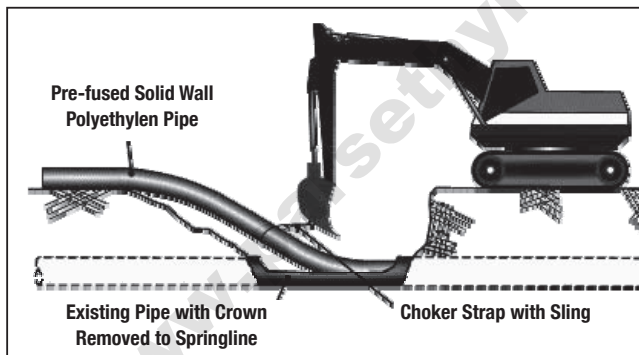

**Figure 10** Pushing Technique for Solid Wall Polyethylene Pipe

Gasketed PE pipe requires the use of the push technique in order to keep the joints from separating, as well as to position the liner. The push technique for gasketed pipe is shown schematically in Figure 10. This process inserts the liner without the necessity for having a high capacity winch and cable system.

### The Combination Technique

The pushing and pulling techniques can sometimes be combined to provide the most efficient installation method. Typically, this arrangement can be used when attempting the placement of unusually heavy walled or long lengths of polyethylene liner.

### Flow Control

For most insertion renewal projects it is not necessary to eliminate the entire flow stream within the existing pipe structure. Actually, some amount of flow can assist positioning of the liner by providing a lubricant along the liner length as it moves through the deteriorated pipe structure. However, an excessive flow can inhibit the insertion process. Likewise, the disruption of a flow stream in excess of 50% of pipe capacity should be avoided.

The insertion procedure should be timed to take advantage of cyclic periods of low flow that occur during the operation of most gravity piping systems. During the insertion of the liner, often a period of 30 minutes or less, the annular space will probably carry sufficient flow to maintain a safe level in the operating sections of the system being rehabilitated. Flow can then be diverted into the liner upon final positioning of the liner. During periods of extensive flow blockage, the upstream piping system can be monitored to avoid unexpected flooding of drainage areas.

Consider establishing a flow control procedure for those gravity applications in which the depth of flow exceeds 50%. The flow may be controlled by judicious operation of pump stations, plugging or blocking the flow, or bypass pumping of the flow stream.

Pressurized piping systems will require judicious operation of pump stations during the liner installation.

### 6. Make Service and Lateral Connections

After the recommended 24-hour relaxation period following the insertion of the polyethylene liner, each individual service connection and lateral can be added to the new system. One common method of making these connections involves the use of a wrap-around service saddle. The saddle is placed over a hole that has been cut through the liner and the entire saddle and gasket assembly is then fastened into place with stainless steel bands. Additional joint integrity can be obtained by extrusion welding of the lap joint created between the saddle base and the liner. The service lateral can then be connected into the saddle, using a readily available flexible coupling<sup>(11)</sup>. Once the lateral has been connected, following standard direct burial procedures can stabilize the entire area.

For pressure applications, lateral connections can be made using sidewall fusion of branch saddles onto the liner. As an alternate, a molded or fabricated tee may be fused or flanged into the liner at the point where the lateral connection is required (see Figures 3 and 4). Mechanical fittings are also a viable option; refer to Chapter 9, PE Joining Procedures, in this Handbook.

7. Make Terminal Connections and Stabilize the Annular Space Where Required  
 Making the terminal connections of the liner is the final step in the insertion renewal procedure. Pressurized pipe systems will require connection of the liner to the various system appurtenances. These terminal connections can be made readily through the use of pressure-rated polyethylene fittings and flanges with fusion technology. Several common types of pressurized terminal connections are illustrated in Figure 11. All of these require stabilization of the transition region to prevent point loading of the liner. Mechanical Joint (MJ) Adapters can be used. Refer to Chapter 9, PE Joining Procedures, in this Handbook.

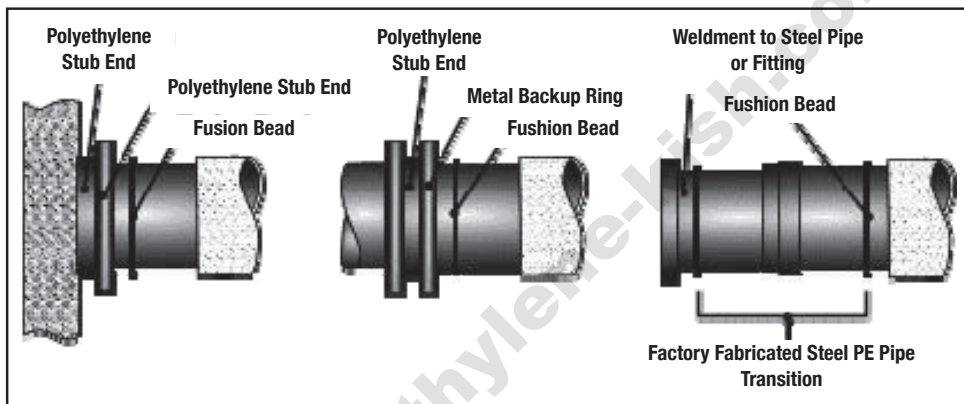

**Figure 11** Terminal and Transition Connections for Pressurized Insertion Renewal Projects

Gravity lines do not typically require pressure-capable connections to the other system appurtenances. In these situations, the annular space will be sealed to prevent migration of ground water along the annulus and, ultimately, infiltration through the manhole or headwall connection. The typical method for making this type of connection is shown in Figure 11. Sealing materials should be placed by gravity flow methods so that the liner’s buckling resistance is not exceeded during installation. Consideration should be given to the specific load bearing characteristics of the fill material in light of the anticipated loading of the liner.

### Other Rehabilitation Methods

Rehabilitation by sliplining is only one (but probably the most popular) of a number of methods using polyethylene pipe currently available for pipeline rehabilitation. As mentioned in the introduction to this chapter, sliplining has been in use for more than thirty years.

Several other methods of rehabilitation that use polyethylene piping will be described briefly here. Please note that, due to rapidly advancing technology, this listing may become incomplete very quickly. Also note that any reference to proprietary products or processes is made only as required to explain a particular methodology.

## Swagelining

A continuous length of polyethylene pipe passes through a machine where it is heated. It then passes through a heated die, which reduces the outside diameter (OD). Insertion into the original pipeline then follows through an insertion pit. The liner pipe relaxes (pressurization may be used to speed the process) until the OD of the liner matches the inside diameter (ID) of the original pipeline. Grouting is not required.

## Rolldown

This system is very similar to swagelining except OD reduction is by mechanical means and expansion is through pressurization.

## Titeliner

A system that is very similar to the swagelining and rolldown systems.

## Fold and Form

Continuous lengths of polyethylene pipe are heated, mechanically folded into a “U” shape, and then coiled for shipment. Insertion is made through existing manholes. Expansion is by means of a patented heat/pressure procedure, which utilizes steam. The pipe is made, according to the manufacturer, to conform to the ID of the original pipeline; therefore, grouting is not required.

## Pipe Bursting

A technique used for replacing pipes made from brittle materials, e.g. clay, concrete, cast iron, etc. A bursting head (or bursting device) is moved through the pipe, simultaneously shattering it, pushing the shards aside, and drawing in a polyethylene replacement pipe. This trenchless technique makes it possible to install pipe as much as 100% larger than the existing pipe.

## Pipe Splitting

A technique, similar to pipe bursting, used for pipes made from ductile materials, e.g. steel, ductile iron, plastic, etc. A “splitter” is moved through the existing pipe, simultaneously splitting it with cutter wheels, expanding it, and drawing in a polyethylene replacement pipe. This trenchless technique is generally limited to replacement with same size or one pipe size (ie., 6” to 8”) larger replacement pipe.

## Summary

This chapter has provided an introductory discussion on the rehabilitation of a deteriorated pipe structure by insertion renewal with continuous lengths of polyethylene pipe. It also includes a brief description of other rehabilitation methods that utilize polyethylene piping. The sliplining or insertion renewal procedure is a cost-effective means by which a new pipeline is obtained with a minimum interference with surface traffic. An inherent benefit of the technology is the installation of a new, structurally sound, leak-free piping system with improved flow characteristics. The resulting pipe structure allows for a flow capacity at or near that of the deteriorating pipe system while eliminating the potential for infiltration or exfiltration. And the best feature of all is the vastly improved longevity of the PE pipe, especially compared to the decay normally associated with piping materials of the past.

The continuing deterioration of this country's infrastructure necessitates innovative solutions to persistent and costly problems. Insertion renewal, or sliplining, is a cost-effective means by which one aspect of the infrastructure dilemma may be corrected without the expense and long-term service disruption associated with pipeline replacement.

## References

1. ASTM 1804, Standard Practice for Determining Allowable Tensile Load for Polyethylene (PE) Gas Pipe During Pull-In Installation, *Annual Book of Standards*, American Society for Testing and Materials (ASTM).
2. ASTM D2321, Standard Practices for Underground Installation of Flexible Thermoplastic Sewer Pipe, *Annual Book of Standards*, American Society for Testing and Materials (ASTM).
3. ASTM D2774, Standard Practices for Underground Installation of Thermoplastic Pressure Piping, *Annual Book of Standards*, American Society for Testing and Materials (ASTM).
4. ASTM D3350, Standard for Polyethylene Pipe and Fittings Materials, *Annual Book of Standards*, American Society for Testing and Materials (ASTM).
5. ASTM F585, Standard Practices for Insertion of Flexible Polyethylene Pipe into Existing Sewers, *Annual Book of Standards*, American Society for Testing and Materials (ASTM).
6. ASTM F714, Standard Specification for Polyethylene (SDR-PR) Based Outside Diameter, *Annual Book of Standards*, American Society for Testing and Materials (ASTM).
7. ASTM F894, Standard Specification for Polyethylene (PE) Large Diameter Profile Wall, Sewer and Drain Pipe, *Annual Book of Standards*, American Society for Testing and Materials (ASTM).
8. Diskin, Joe. (1987, May). Plastic Pipe Insertion, (NF), *Pipeline and Gas Journal*.
9. *Driscopipe System Design*. (1985, January). A Publication of Phillips Driscopipe, Inc.
10. Elastizell Product Catalog. (1984). *The Elastizell Advantage*. A Publication of the Plastizell Corporation of America.
11. *Existing Sewer Evaluation and Rehabilitation*. (1983). American Society of Civil Engineers and the Water Environment Federation, New York, NY.
12. *Fernco Product Catalog 185*. (1985, January). A Publication of Ferncom, Inc.
13. Gross, Sid. (1985, May). Plastic Pipe in Gas Distribution, Twenty-Five Years of Achievement, *Gas Industries*.
14. Gross, Sid. (1987, September). Choosing Between Liners for Sewer Rehabilitation, *Public Works*.
15. *Handbook of PVC Pipe*. (1978, February). A Publication of the Uni-Bell Plastic Pipe Association, Dallas, TX.
16. Howard, A.E., & Selander, C.E., (1977, September). Laboratory Load Tests on Buried Thermosetting, Thermoplastic and Steel Pipe, *Journal AWWA*.
17. Jenkins, C.F. & Kroll, A.E. (1981, March 30-April 1). External Hydrostatic Loading of Polyethylene Pipe, Proceedings of the International Conference on Underground Plastic Pipe, sponsored by the Pipeline Division of the American Society of Civil Engineers.
18. Lake, Donald W., Jr. (1979, December). Innovative Rehabilitation of Embankment Conduits. Paper presented to the 1984 winter meeting of the American Society of Agricultural Engineers.
19. Plastics Pipe Institute. (1979, September). Technical Report TR-31, Underground Installation of Polyolefin Piping.
20. *Polyolefin Piping*. (1985, May). A Publication of the Plastics Pipe Institute, Irving, TX.

21. *Recommended Specifications for Sewer Connection Rehabilitation.* (1984, January). A Publication of the National Society of Service Companies.
22. *Renewing Sewers with Polyolefin Pipe.* (1985, June). A Publication of the Plastics Pipe Institute, Irving, TX.
23. Sandstrum, S.D. (1986, August). Sewer Rehabilitation with Polyethylene Pipe. Paper presented at the Second Annual Sewer Maintenance and Rehabilitation Conference, Center for Local Government Technology, Oklahoma State University.
24. Schock, David B. (1982, August 6). New Pipes Do Job Better, *Mount Pleasant Morning Sun*.
25. Spangler, M.G. (1941). The Structural Design of Flexible Pipe Culverts, Bulletin 153, Iowa State Engineering Experiment Station.
26. *Spiral Engineered Systems*, A Publication of Spirolite, a Subsidiary of the Chevron Corporation.
27. Watkins, R.K. (1977). *Buried Structures*, Foundation Engineering Handbook, Utah State University.
28. Watkins, R.K. (1977). *Principles of Structural Performance of Buried Pipes*, Utah State University.
29. DOT FHWA-1P-85-15.
30. *Mark's Handbook for Mechanical Engineers*, 10th Edition.
31. Larock, B.E., Jeppson, R.W., & Watters, G.Z. (2000). *Hydraulics of Pipeline Systems*, Boca Raton: CRC Press.
32. Lo, King H., & Zhang, Jane Q. (1994, February 28-March 2). Collapse Resistance Modeling of Encased Pipes, Buried Plastic Pipe Technology: 2nd Volume, Papers presented at the ASTM symposium, New Orleans.